

Simulation Analysis of FACTS Devices for Transient Stability Improvement in Multi Machine System

Kamal Singh

Department of Electrical and Electronics Engineering RKDF College of Engineering Bhopal.

Abstract: Transient stability control plays an important role in ensuring the stable operation of power systems in the experience of large disturbances and faults, and is thus an important area of research. This paper investigates the relationship of SVC, STATCOM and UPFC performance for the transient stability improvement of the power system. The enhancement of transient stability of the power system, using SVC (Static VAR Compensator), STATCOM (Static Synchronous Compensator) and UPFC (Unified Power Flow Controller) which is an effective FACTS (Flexible AC Transmission System) device able of controlling the active and reactive power flows in a transmission line by controlling appropriately parameters. Simulations are carried out in Matlab/Simulink environment. The presentation of SVC, STATCOM & UPFC is compared from each other. So for the improvement of transient stability STATCOM is superior than SVC. The simulation results demonstrate the value and robustness of the proposed STATCOM, UPFC & SVC on transient stability improvement of the system.

Keywords: FACTS, SVC, STATCOM, UPFC, Matlab/ Simulink, Transient stability

1. INTRODUCTION

Modern power system is a difficult network comprise of numerous generators, transmission lines, variety of loads and transformers. As a result of increasing power demand, some transmission lines are more loaded than was intended when they were built. With the increased loading of long transmission lines, the difficulty of transient stability after a major fault can become a transmission limiting factor [1]. Now power engineers are much more afraid about transient stability problem due to blackout in northeast United States, Scandinavia, England and Italy. Transient stability refers to the ability of a system to maintain synchronous operation in the event of large disturbances such as multi-phase short-circuit faults or switching of lines [2]. The resulting system answer involves large excursions of generator rotor angles and is influenced by the nonlinear power angle relationship. Stability depends ahead both the initial operating conditions of the system and the severity of the disturbance. Latest development of power electronics introduces the use of flexible ac transmission system (FACTS) controllers in power systems. FACTS controllers are able of controlling the network condition in a very fast manner and this feature of FACTS can be exploited to improve the voltage stability, and steady state and transient stabilities of a difficult power system [3-4]. This allows increased utilization of existing network closer to its thermal loading capacity, and thus avoiding the require to construct new transmission lines. Static VAR Compensator (SVC) is a first generation FACTS device that can control voltage at the required bus thereby improving the voltage profile of the system. The

main task of an SVC is to maintain the voltage at a particular bus by means of reactive power compensation (obtained by varying the firing angle of the thyristors) [5]. SVCs have been used for high performance steady state and transient voltage control compared with standard shunt compensation. SVCs are also used to dampen power swings, improve transient stability, and decrease system losses by optimized reactive power control [6-7]. STATCOM, a shunt compensation device, from the family of flexible alternating current transmission systems (FACTS). The STATCOM is a solid-state voltage source converter which is tied to a transmission line. A STATCOM injects an almost sinusoidal current, of changeable magnitude, at the point of connection. This injected current is approximately in quadrature with the line voltage, thereby emulating an inductive or a capacitive reactance at the point of connection with the transmission line. The profit of utilizing FACTS devices in electrical transmission systems can be summarized as follows:

1. Better utilization of presented transmission system assets
 2. improved transmission system reliability and availability
 3. Increased dynamic and transient grid stability and decrease of loop flows
 4. Better quality of supply for sensitive industries
- Environmental profit.

2. STATIC VAR COMPENSATOR (SVC)

Static VAR systems are applied by utilities in transmission applications for several purposes. The primary purpose is usually for rapid control of voltage at weak points in a network. Installations may be at the midpoint of transmission interconnections or at the line ends. Static VAR Compensators are shunt connected static generators/ absorbers whose outputs are different so as to control voltage of the electric power systems. In its easy form, SVC is connected as Fixed Capacitor Thyristor Controlled Reactor (FC-TCR) configuration as shown in Figure 1.

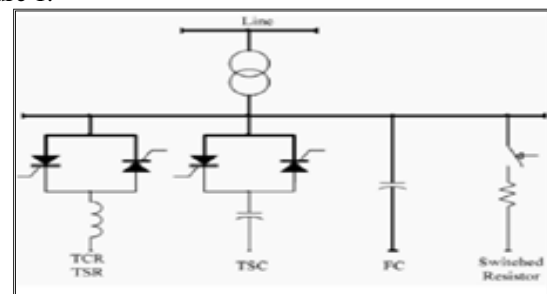

Figure 1: Static VAR Compensator (SVC)



Simulation Analysis of FACTS Devices for Transient Stability Improvement in Multi Machine System

The SVC is connected to a coupling transformer that is linked directly to the ac bus whose voltage is to be regulated. The efficient reactance of the FC-TCR is varied by firing angle control of the anti-parallel thyristors. The firing angle can be controlled during a PI (Proportional + Integral) controller in such a way that the voltage of the bus, where the SVC is connected, is maintained at the reference value.

3. STATIC SYNCHRONOUS COMPENSATOR (STATCOM)

The STATCOM is based on a solid state synchronous voltage source which generates a objective set of three sinusoidal voltages at the fundamental frequency with quickly controllable amplitude and phase angle. The relationship of a line voltage, thereby emulating an inductive or a capacitive reactance at the position of connection with the transmission line. STATCOM is shown in Figure 2.

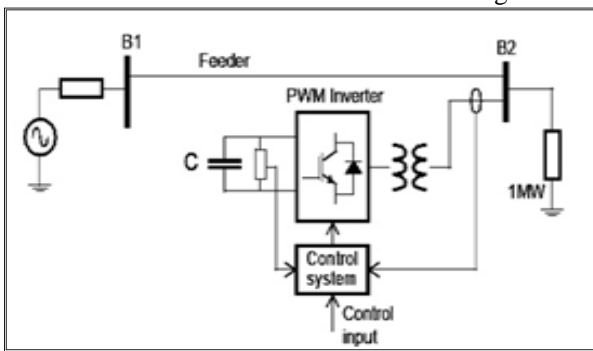

Figure 2: Static Synchronous Compensator (STATCOM)

4. UNIFIED POWER FLOW CONTROLLER (UPFC)

Unified power flow control is apparatus nothing but a combination of series & shunt facts device & it clearly do the same work what is done by the series & shunt fact device alone. It is the most influential facts device [7]. UPFC is mainly a combination of SSSC & STATCOM. Used to advance the transient stability of the power system [8].The schematic figure of unified power flow controller is given below.

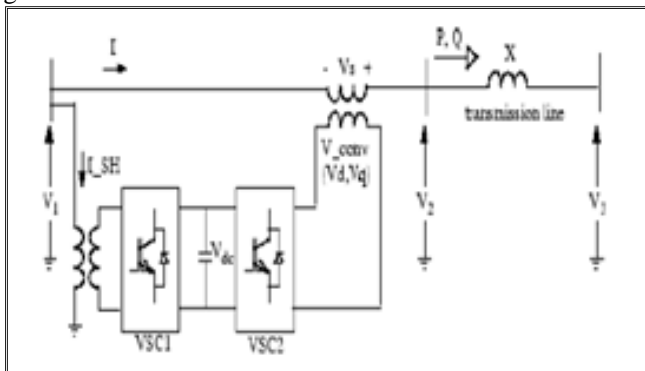

Figure 3: Unified Power Flow Controller (UPFC)

5. SIMULATION MODEL AND RESULTS

All the FACTS devices like SVC, STATCOM and UPFC are compared with the simulation analysis in MATLAB simulink.

5.1 IMPACT OF SVC (LLL-G FAULT)

When apply a 3-phase fault and observe that impact of the SVC for stabilizing the network for the period of a severe possibility. First put the two PSS in service. Reprogram the Fault Breaker of simulation block to apply a 3-phase-to-ground fault. Verify that the SVC is in fixed susceptance mode with $B_{ref} = 0$, The rating of the SVC is +/-200MVA when at the Start of simulation. By looking at the d_theta1_2 signal, you must observe that the two machines quickly drop out of synchronism after fault clearing. In order not to track pointless simulation, the Simulink Stop block is used to stop the simulation when the angle difference reaches $3*360$ degrees. at this time open the SVC block menu and change the SVC mode of procedure to Voltage regulation. The SVC will now attempt to take the voltage by injecting reactive power on the line when the voltage is lesser than the reference voltage (1.0 pu). The selected SVC reference voltage corresponds to the bus voltage with the SVC out of service. In steady state the SVC will therefore be balanced and approaching up for voltage compensation when voltage departs from its reference set point. Let we installed SVC at bus 2, and 3-phase fault at same place as shown in fig. 5.1.

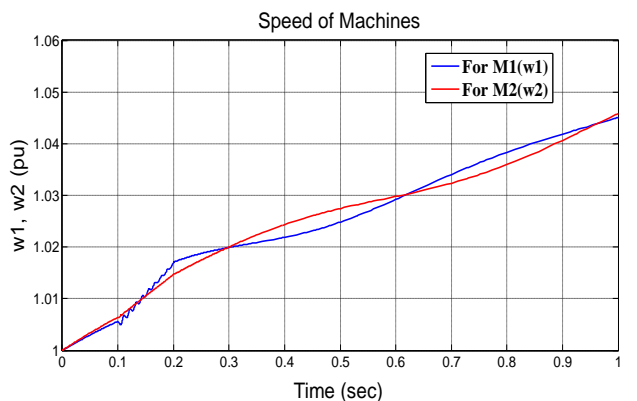
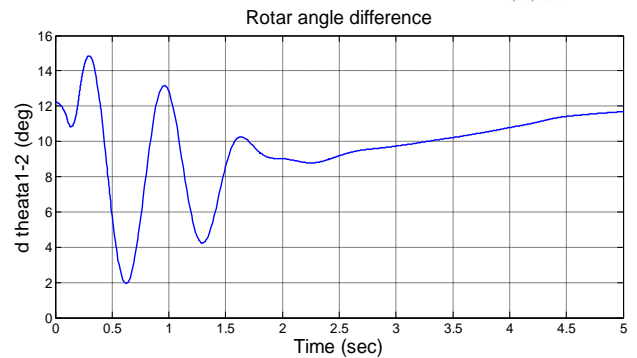
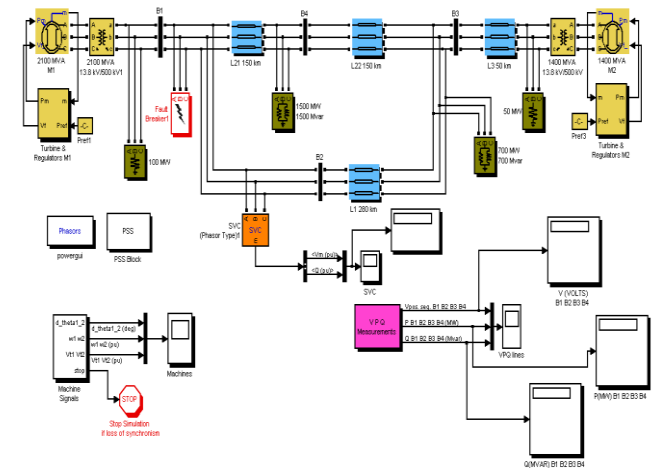

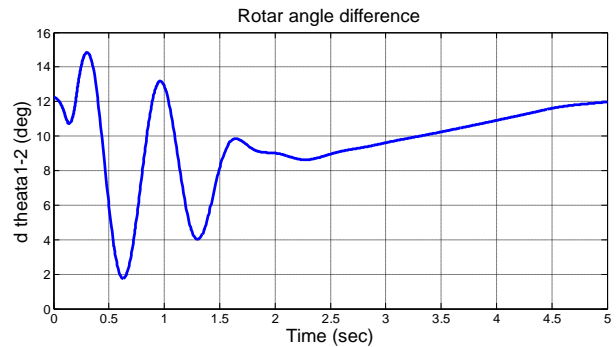
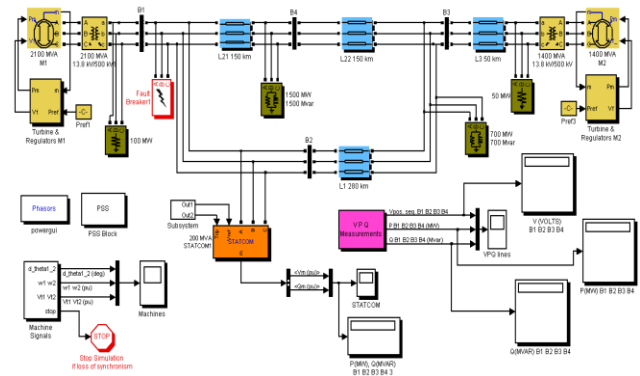
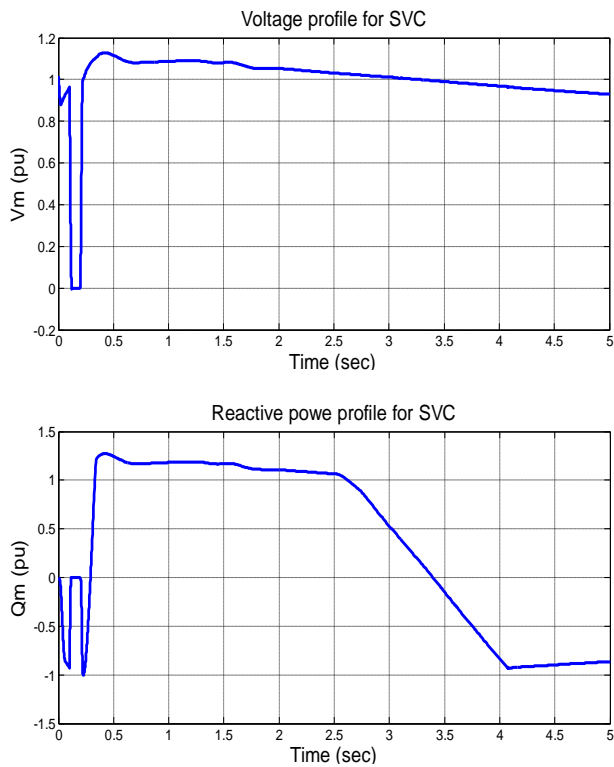
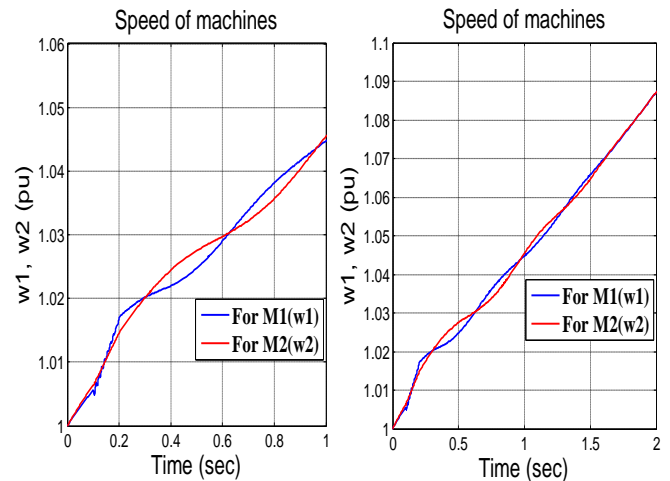

Fig.5.1 Waveforms for SVC with 3-Phase (LLL-G) Fault, (a) Rotor angle difference, (b) Speed of machines, (c) Voltages profile, (d) Reactive power profile.

Table 5.1 Reactive power & voltages with SVC

Bus	Q (Mvar)	V (k volts)
B1	591.6	464.7
B2	13.11	464.4
B3	-559.3	437.1
B4	-371.5	391.1



5.2 IMPACT OF STATCOM (LLL-G FAULT)

The Static Synchronous Compensator (STATCOM) is single of the input FACTS devices. STATCOM output current (inductive or capacitive) be able to controlled self-determining of the AC system voltage. The power grid consists of two 500-kV equivalents transmission line. The STATCOM is located at bus B2 and has a rating of +/-200MVA. This STATCOM is a phasor model of a typical three-level PWM STATCOM. but you release the STATCOM block and select "Display Power data", you will monitor that our model represent a STATCOM having a DC link nominal voltage of 40 kV with an equivalent capacitance of 375 μ F. On the AC side, its total equivalent impedance is 0.22 pu on 200 MVA. This impedance represents the transformer leakage reactance and the phase reactor of the IGBT bridge of an actual PWM STATCOM. Simulation is showing in below for STATCOM with 3-phase fault (LLL-G).

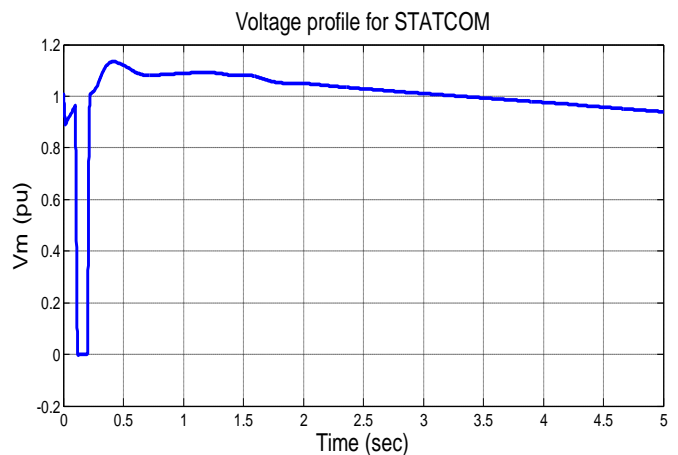

Simulation Analysis of FACTS Devices for Transient Stability Improvement in Multi Machine System

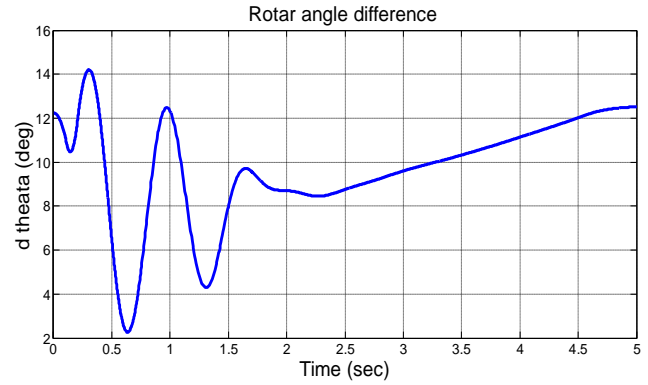
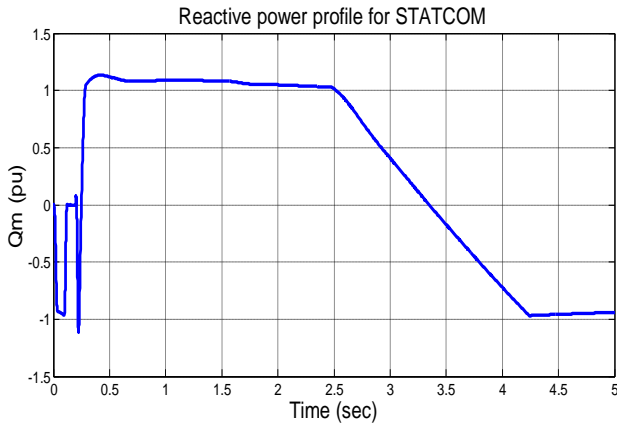
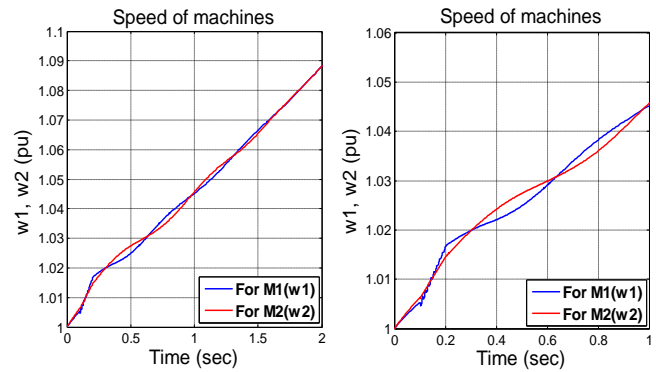

Fig.5.2 Waveforms for STATCOM with 3-Phase (LLL-G) Fault, (a) Rotor angle difference, (b) Speed of machines, (c) Voltages profile, (d) Reactive power profile.

Table 5.2 Reactive power & voltages with STATCOM

Bus	Q (Mvar)	V (k volts)
B1	483.3	469.8
B2	15.83	469.8
B3	-569.3	437.1
B4	-379.1	395.2



5.3 IMPACT OF UPFC (LLL-G FAULT)

The system, connected in a loop arrangement, consists basically of four buses (B1 to B4). The rating of UPFC is +/-200MVA for both series and shunt controller. The UPFC located at bus B2 is used to control the active and reactive powers at the 500-kV. It consists of a phasor model of two 200-MVA, IGBT-based, converters (one converter connected in shunt and one more converter connected in series and both interconnected through a DC bus on the DC side and to the AC power system, from side to side coupling reactors and transformers). Parameters of the UPFC power components are given in the dialog box. Open the UPFC dialog box and select "Display Control parameters (series converter)". The organize parameters of the series converter are display. prove that "Mode of operation = Power flow control". The UPFC reference active and reactive powers are set inside the blocks as a "Pref(pu)" and "Qref(pu)". primarily the Bypass breaker is closed and the resulting natural power flow at bus B2. The simulation intended for the UPFC is shown in the fig. 5.3

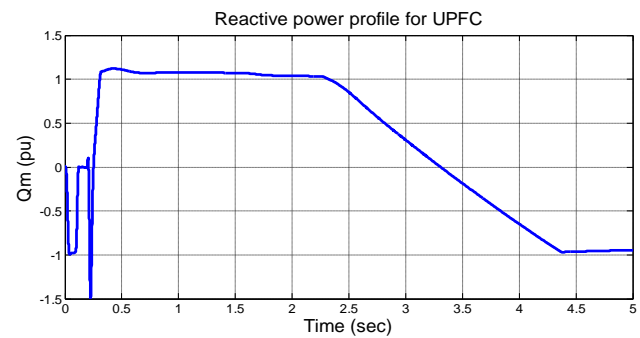
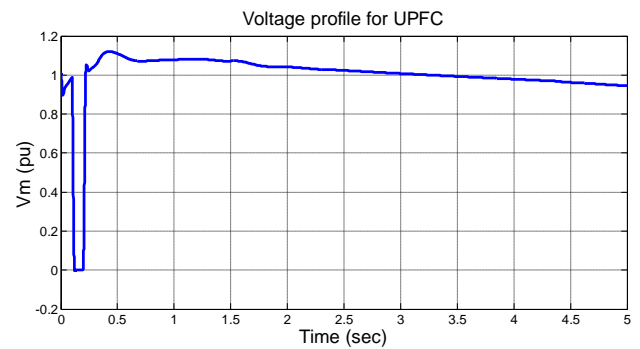
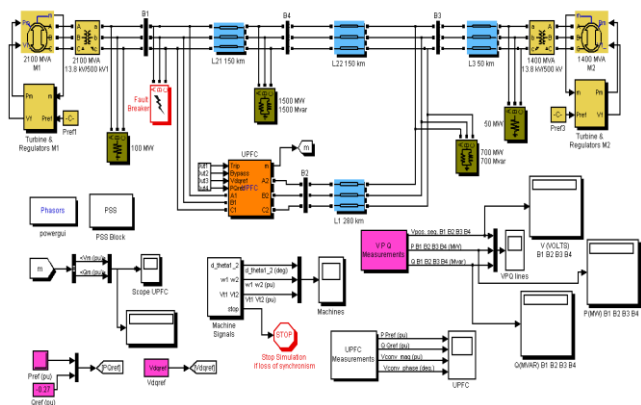

Fig.5.3 Waveforms for UPFCwith 3-Phase (LLL-G) Fault, (a) Rotor angle difference, (b) Speed of machines, (c) Voltages profile, (d) Reactive power profile.

Table 5.3 Reactive power & voltages with UPFC

Bus	Q (Mvar)	V (k volts)
B1	403.6	473.1
B2	22.26	471.1
B3	-557.4	438.1
B4	-374.9	395.8



6. CONCLUSION

The comparison of the SVC, STATCOM and UPFC, controller applications. The detailed models of the SVC, STATCOM, and UPFC were implemented and tested in the EMT (electro-magnetic transients). The models are relevant for transient stability analysis, and cover broader range of frequency oscillations and voltage control.

The STATCOM give better performance than SVC for reactive power, voltages and loading capacity. For STATCOM reactive power compensated from 13.11 MVAR (SVC) to 15.83 MVAR (STATCOM) and voltage injected from 464.4 kv (SVC) to 469.8 kv (STATCOM) at bus 2. another relation with UPFC give better-quality performance than STATCOM for reactive power, voltages and loading capacity. For UPFC reactive power compensated from 15.83 MVAR (STATCOM) to 22.26 MVAR (UPFC) and voltage injected from 469.8 kv (STATCOM) to 471.1 (UPFC) kv at bus 2 and table no. 5.2 & 5.3.

REFERENCES

- [1]. M. Faridi & H. Maeiati, M. Karimi & P. Farhadi, H. Mosleh, 'Power System Stability Enhancement Using Static Synchronous Series Compensator (SSSC)' 978-1-61284-840-2/11/\$26.00 ©2011 IEEE.
- [2]. Ding Lijie, Liu Yang, Miao Yiqun 'Comparison of high capacity SVC and STATCOM in real power grid' 978-0-7695-4077-1/10 \$26.00 © 2010 IEEE, DOI 10.1109/ICICTA.2010.586.
- [3]. Hirdesh Chaturvedi, Paramjeet Kaur. Comparative Analysis of Voltage profile Enhancement using "FACTS" Devices. International Research Journal of Engineering & Applied Sciences, IRJEAS, 2(4), pp. 06-10, 2014. https://www.irjeas.org/wp-content/uploads/admin/volume2/V2I4/V2I4_10141214_0003.pdf.
- [4]. Reena Singh, Pallavi Bondriya, Mitali Kushwaha. ANALYSIS AND COMPARISON OF VARIOUS FACTS DEVICES. International Research Journal of Engineering & Applied Sciences, IRJEAS, 4(1), pp. 15-17, 2016. <https://www.irjeas.org/wp-content/uploads/admin/volume4/V4I1/IRJEAS04V4I101160316000081.pdf>.
- [5]. Saurav Vishwakarma and Prof. R.K. Tripathi, 'Transient Energy Dissipation and Damping Improvement using STATCOM & SSSC' 978-1-4244-8542 0/10/\$26.00 ©2010 IEEE.
- [6]. Prashant Rajotia, Dr. Deepika Masand. POWER SYSTEM STABILITY IMPROVEMENT OF MULTI MACHINE SYSTEM BY USING STATCOM. International Research Journal of Engineering & Applied Sciences, IRJEAS, 4(3), pp. 01-04, 2016. <https://www.irjeas.org/wp-content/uploads/admin/volume4/V4I3/IRJEAS04V4I307160916000085.pdf>.
- [7]. Xu Ting, Jiang Daozhuo, Guo Jie, Shentu Gang, Zhang Qian, 'Analyzing a novel controllable rectifier type SVC and de-icing device's impact on the transient stability of power system' 978-1-4244-5940-7/1101/\$26.00/1D2010 IEEE.
- [8]. Aastha Kashiv, Dr. C. S. Rajeshwari. Transient Stability Enhancement using Unified Power Flow Controller in Multi-Machine System. International Research Journal of Engineering & Applied Sciences, IRJEAS, 2(3), pp. 39-46, 2014. https://www.irjeas.org/wp-content/uploads/admin/volume2/V2I3/V2I3_07140914_0010.pdf.
- [9]. Morison, K., Wang, L., Kundur, P., Lin, X., Gao, W., He, C., Xue, F., Xu, J., Xu, T., and Xue, Y.: 'Critical requirements for successful on-line security assessment' Proc. IEEE PES PSC&E Conf., New York, 10 – 13 Oct 2004.
- [10]. Anurag Shrivastava, Jyoti Sondhi, Sadaf Khan. AN IMPLEMENTATION OF INTRUSION DETECTION SYSTEM USING MACHINE LEARNING CLASSIFICATION TECHNIQUE. International Research Journal of Engineering & Applied Sciences, IRJEAS, 5(2), pp. 14-17, 2017. <https://www.irjeas.org/wp-content/uploads/admin/volume5/V5I2/IRJEAS04V5I204170617000002.pdf>.
- [11]. H. Saadat, Power System Analysis McGraw-Hill International Editions, 1999.
- [12]. Upendra Sah, Santosh Kumar. A REVIEW ON EFFICIENT FAULT DIAGNOSIS SCHEME FOR PV SYSTEM USING MACHINE LEARNING TECHNIQUES IN THE DC SIDE. International Research Journal of Engineering & Applied Sciences, IRJEAS, 8(3), pp. 17-21, 2020. <https://www.irjeas.org/wp-content/uploads/admin/volume8/V8I3/IRJEAS04V8I307200920000003.pdf>.
- [13]. Rajshri Pohekar, Vaibhav Patel, Anurag Shrivastava. CYBER ATTACK DETECTION AND CLASSIFICATION USING MACHINE LEARNING TECHNIQUE USING MICROSOFT AZURE CLOUD. International Research Journal of Engineering & Applied Sciences, IRJEAS, 5(2), pp. 32-35, 2017. <https://www.irjeas.org/wp-content/uploads/admin/volume5/V5I2/IRJEAS04V5I204170617000009.pdf>.
- [14]. Ahsanul Alam, and M. A. Abido, 'Parameter Optimization of Shunt FACTS Controllers for Power System Transient Stability Improvement' 978-1-4244-2190-9/07/\$25.00 ©2007 IEEE.
- [15]. Huang Shao-Ping, Jin Guo-Bin, Li Ling, 'Modeling and Simulating for Transient Stability Analysis of Power System using Dynamic Phasor' 978-0-7695 3887-7/09/\$26.00 ©2009 IEEE.
- [16]. Brajesh Jangid, Dr. Ravindra Mohan Saxena. DESIGN & DEVELOPMENT A PISTON HEAD FOR INTERNAL COMBUSTION ENGINE USING COORDINATE MEASURING MACHINE- A REVIEW. International Research Journal of Engineering & Applied Sciences, IRJEAS, 3(4), pp. 05-08, 2015. <https://www.irjeas.org/wp-content/uploads/admin/volume3/V3I4/IRJEAS04V3I4101512150002.pdf>.
- [17]. T.T. Nguyen and S. R. Wagh, 'Model Predictive Control of FACTS Devices for Power System Transient Stability' IEEE T&D Asia 2009.
- [18]. Using NLTK (Natural Language Toolkit). In: Khanna, A., Gupta, D., Kansal, V., Fortino, G., Hassanien, A.E. (eds) Proceedings of Third Doctoral Symposium on Computational Intelligence. Lecture Notes in Networks and Systems, vol 479. Springer, Singapore. https://doi.org/10.1007/978-981-19-3148-2_37
- [19]. Gupta, K., Jiwani, N., Whig, P. (2023). An Efficient Way of Identifying Alzheimer's Disease Using Deep Learning Techniques. In: Khanna, A., Gupta, D., Kansal, V., Fortino, G., Hassanien, A.E. (eds) Proceedings of Third Doctoral Symposium on Computational Intelligence. Lecture Notes in Networks and Systems, vol 479. Springer, Singapore. https://doi.org/10.1007/978-981-19-3148-2_38
- [20]. Gupta, K., Jiwani, N., Whig, P. (2023). Effectiveness of Machine Learning in Detecting Early-Stage Leukemia. In: Gupta, D., Khanna, A., Bhattacharyya, S., Hassanien, A.E., Anand, S., Jaiswal, A. (eds) International Conference on Innovative Computing and Communications. Lecture Notes in Networks and Systems, vol 471. Springer, Singapore. https://doi.org/10.1007/978-981-19-2535-1_34
- [21]. Telli Haman, Ahad Kazemi, 'Improvement of Power System Transient Stability by Two Control Methods: Study and Simulation' IEEE International Symposium on Industrial Electronics (ISIE 2009) Seoul Olympic Parktel, Seoul, Korea July 5-8, 2009.
- [22]. Vani, Paramjeet Kour. Harmonic Analysis of Symmetrical and Asymmetrical Inverters. International Research Journal of Engineering & Applied Sciences, IRJEAS, 2(2), pp. 34-43, 2014. https://www.irjeas.org/wp-content/uploads/admin/volume2/V2I2/V2I2_04140614_0009.pdf.
- [23]. J.S. Uprit, Dr. A.M. Shandilya. Optimal Design of PV-WTG Hybrid Energy System. International Research Journal of Engineering &



Simulation Analysis of FACTS Devices for Transient Stability Improvement in Multi Machine System

Applied Sciences, IRJEAS, 2(2), pp. 44-48, 2014.
https://www.irjeas.org/wp-content/uploads/admin/volume2/V2I2/V2I2_04140614_0006.pdf.

- [24]. Jiwani, N., Gupta, K., Whig, P. (2023). Analysis of the Potential Impact of Omicron Crises
- [25]. Jiwani, N., Gupta, K., Whig, P. (2023). Assessing Permeability Prediction of BBB in the Central Nervous System Using ML. In: Gupta, D., Khanna, A., Bhattacharyya, S., Hassanien, A.E., Anand, S., Jaiswal, A. (eds) International Conference on Innovative Computing and Communications. Lecture Notes in Networks and Systems, vol 471. Springer, Singapore. https://doi.org/10.1007/978-981-19-2535-1_33
- [26]. Gupta, Ketan and Jiwani, Nasmin, Prediction of Insulin Level of Diabetes Patient Using Machine Learning Approaches (January 18, 2022). KetanGupta,NasminJiwani, 'Prediction of Insulin Level of Diabetes Patient Using Machine Learning Approaches', International Journal of Creative Research Thoughts (IJCRT), ISSN:2320-2882, Volume.10, Issue 8, pp.c434-c441, August 2022, Available at :<http://&>, Available at SSRN: <https://ssrn.com/abstract=4205251>