

Implementation of UPFC In Intelligent Control And Dynamic Performance Enhancement

Amar Singh

M. Tech Scholar, Department of Electrical & Electronics Engineering, JEC, Jabalpur, M.P., India

Diwaker Kumar

M. Tech Scholar, Department of Electrical & Electronics Engineering, JEC, Jabalpur, M.P., India

Abstract- Due to the increasing demand of electricity the quantity of nonlinear load also get increased. Hence due to the increase in non-linear load it is being difficult to maintain the stability and security of the power system. In order to overcome from this difficulty a new approach fuzzy logic with UPFC is used in this paper. This intelligent control system is applied which enhances the transmission system. Fuzzy system uses the membership function which is designed to improve the system performance. In this research papera MATLAB simulationis being carried out on a four bus system using UPFC Controller and fuzzy logic.

Keywords: - FLC Controller, Flexible AC Transmission System, UPFC, Mamdani Interface, STATCOM.

I. INTRODUCTION

UPFC is a dynamic controller and it is an advance form of FACTS device and it can provide the control of voltage as well as active and reactive power flows in the system [1]. UPFC is a combination of series and shunt controller device and hence it provides series as well as shunt compensation. UPFC consist of STATCOM and SSSC. STATCOM is Static Synchronous Compensator and it is based on voltage source or current source converter. SSSC is Static Synchronous Series Capacitor it includes rated energy storage or energy absorbing devices to enhance the dynamic behaviour of power system. By damping the low power system oscillations the UPFC can be used for the improvement of transient stability improvement [2]. Fuzzy logic provides a general thought for description and measurement. Most FLC systems encrypt human reasoning into a program to create selections or management a system [3]-[4].

FLC contains fuzzy sets, which are a form of representing non-statistical uncertainty and approximate reasoning, which incorporates the operations accustomed that build inferences in FLC. In FLC case, a UPFC damping controller style which uses FLC theme which supports the Mamdani reasoning engine by the application of the middle of Gravity technique to seek out the controller output is conferred here. Totally different load conditions area unit thought of to indicate effectiveness of the projected ways.

Most fuzzy controllers are designed supported human operator expertise and/or management engineer knowledge. It is, however, typically the case that the operator can't tell lingual what quite action he takes in a very particular state of affairs. During this respect it's quite helpful to administer a way to model his management actions victimisation numerically.

II. UNIFIED POWER FLOW CONTROLLER

A unified power flow controller (UPFC) is that the most promising device within the FACTS thought. These devices has the power to regulate the basic parameters, i.e. the bus voltage, line reactance, and the phasor angle between the buses, either at the same time or may be separately. A UPFC performs this through the management of the in-phase voltage, quadrature voltage, and shunt compensation.

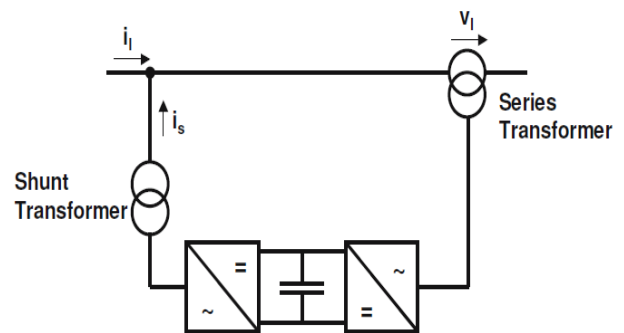

Fig 1. Principle Configuration of UPFC

The UPFC is one of the versatile device and sophisticated power equipment that has emerged for the management and optimization of power flow in power transmission system. It offers major potential benefits for the static and dynamic operation of transmission line. The UPFC was devised for the period management and dynamic compensation of AC transmission system, providing multifunctional flexibility needed to resolve several issues facing the power system.

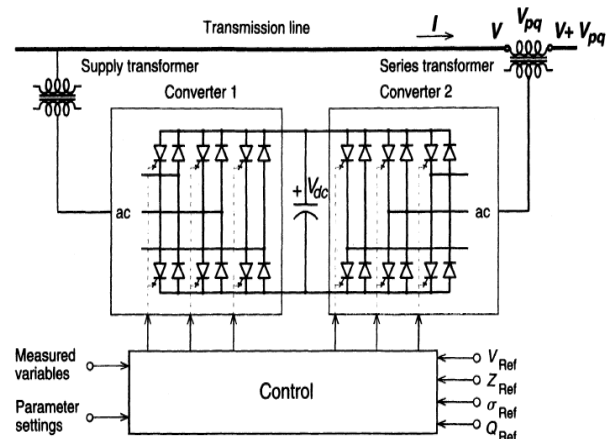

Fig 2. UPFC Control Structure



III. FUZZY LOGIC CONTROLLER

There is additional to fuzzy logic than some fascinating science, it consist of some important applications in engineering. The important application of fuzzy logic in engineering is within the space of management systems. The definition of an impact system, given by Richard in trendy management Systems is: "An interconnection of components forming a system configuration that may give a desired response". This suggests that an impact system has to apprehend the required response (input) and it has to method this input and conceives to achieve it. The overall system will then be summarized with the subsequent diagram:

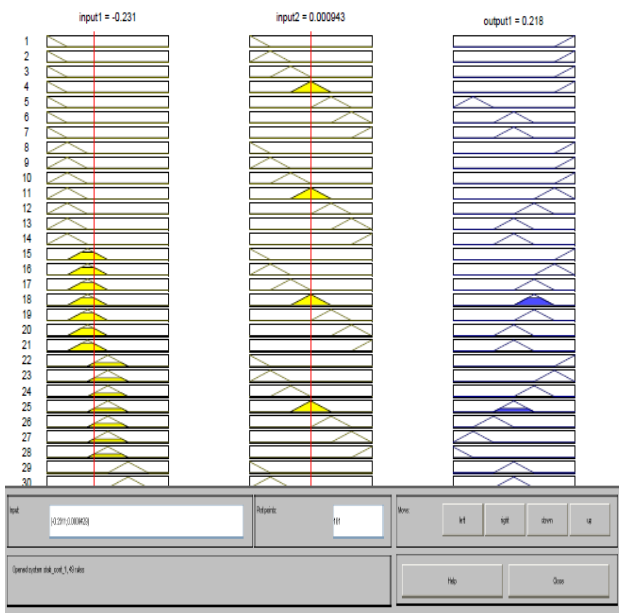

Fig 3. Rule Viewer of FLC

The method is that the system that is being controlled and can't generally be modified. The controller then should take the input and additionally take measurements from the method and use this data to come up with the acceptable input to the method. A basic example of a controller would be a summing purpose that may give the distinction between input and output to the method, whereas an additional advanced controller would be a PID controller. A mathematical logic based mostly controller can use fuzzy membership functions and illation rules to see the acceptable method input. Coming up with a fuzzy controller could be an additional approach to controller style since it uses a comprehensible concept base.

Fuzzy controllers are often weakened into 3 main processes. The primary of those is that the fuzzification, this uses outlined membership functions to method the inputs and to fuzzify them. These fuzzified inputs square measure then employed in the second half, the rule-based illation system. This method uses antecedently outlined linguistic rules to come up with a fuzzy response. The fuzzy response is then defuzzified within the final process: defuzzification. This tool case provides a interface for outlining membership functions and illation rules and may be integrated with Simulink.

| | NL | NM | NS | Z | PS | PM | PL |
|---|----|----|----|----|----|----|----|
| N | PS | PL | PL | PS | NM | NS | NM |
| S | | | | | | | |
| N | PM | PL | PL | PM | Z | Z | Z |
| M | | | | | | | |
| N | PL | PL | PL | PL | Z | Z | Z |
| L | | | | | | | |
| Z | PS | PM | PL | Z | NS | NM | NL |
| P | PS | PS | NM | NS | NS | NL | NL |
| S | | | | | | | |
| P | Z | Z | Z | NM | NM | NL | NL |
| M | | | | | | | |
| P | Z | Z | Z | NL | NL | NL | NL |
| L | | | | | | | |

Table 1. Fuzzy logic truth table

IV. SIMULATION AND RESULTS

The Simulation is being carried out on the four bus system. The simulation model and the results can be as shown :-

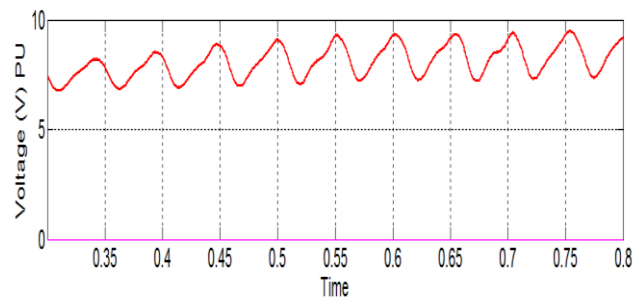

Fig 4. Simulation Model

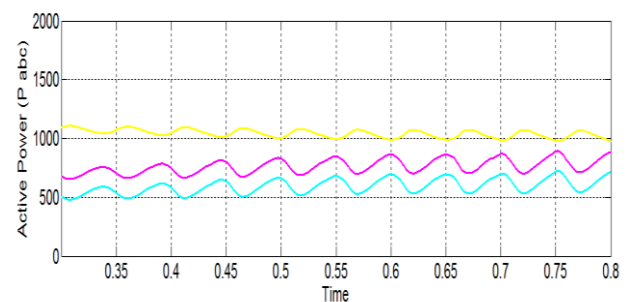

Fig5. Output Voltage waveform

V. CONCLUSION

The results shows that by the application of fuzzy logic and UPFC controller the transmission capability of the system enhances hence by reducing the harmonics from the system.

REFERENCES

- [1]. Djilani Kobibi, Youcef Islam, Hadjeri Samir, Djehaf Mohammed Abdeldjalil. "Independent Power Flow Control and Dynamic Performance Enhancement by the UPFC". ICEIT'2015.
- [2]. N. G. Hingorani and L.Gyugyi, "Understanding FACTS: Concepts and Technology of Flexible AC Transmission Systems", New York: IEEE Press, 2000.
- [3]. Rakesh Pal, Dr. V.K. Sethi, Anurag Gour. Assessing the Performance of 100 kW Solar PV Power-plants Through I-V Characterization & Validation of Tilted Irradiance Calculation Compared to an Hourly Model. International Research Journal of Engineering & Applied Sciences, IRJEAS, 2(1), pp. 01-09, 2014. https://www.irjeas.org/wp-content/uploads/admin/volume2/V2I1/V2I1_01140314_0003.pdf.
- [4]. Mr.P.S.Chindhi, Prof.H.T.Jadhav, Mr.V.S.Patil, "A comprehensive survey for optimal location and coordinated control techniques for FACTS controller in power system environment and applications", IOSR Journal of Electronics and communication engineering (IOSR-JECE), ISSN: 2278-2834, ISBN: 2278-8735.
- [5]. Arun Kumar. Power Utilization Through Braking System. International Research Journal of Engineering & Applied Sciences, IRJEAS, 1(3), pp. 14-20, 2013. https://www.irjeas.org/wp-content/uploads/admin/volume1/V1I3/IRJEAS04_V1I3_07130913_0004.pdf.
- [6]. Douglas J. Gotham, G. T. Heydt, "Power Flow control and power flow studies for system with facts devices", IEEE Transactions on Power Systems, Vol. 13, No. 1, February 1998.
- [7]. Shailesh Sharma, Paramjeet Kour. HVDC Power Transmission & Technology in India. International Research Journal of Engineering & Applied Sciences, IRJEAS, 2(1), pp. 34-40, 2014. https://www.irjeas.org/wp-content/uploads/admin/volume2/V2I1/V2I1_01140314_0007.pdf.
- [8]. Nikhlesh Kumar Sharma, Arindam Ghosh, Rajiv Kumar Varma, "A Novel Placement Strategy for Facts Controllers, IEEE Transactions on power delivery, Vol 8, No.3, July 2003.
- [9]. Diksha Rani Singh, Sourabh Gupta. Simulink Model of Shunt Active Power Filter Using Instantaneous Power Theory. International Research Journal of Engineering & Applied Sciences, IRJEAS, 2(2), pp. 12-15, 2014. https://www.irjeas.org/wp-content/uploads/admin/volume2/V2I2/V2I2_04140614_0003.pdf.
- [10]. T. Takagi, M. Sugeno, "Fuzzy Identification of Systems and Its Applications to Modeling and Control". IEEE Transaction on systems, Man and Sybern, Vol. 1985, pp. I: 116-132.
- [11]. Aastha Kashiv, Dr. C. S. Rajeshwari. Transient Stability Enhancement using Unified Power Flow Controller in Multi-Machine System. International Research Journal of Engineering & Applied Sciences, IRJEAS, 2(3), pp. 39-46, 2014. https://www.irjeas.org/wp-content/uploads/admin/volume2/V2I3/V2I3_07140914_0010.pdf.
- [12]. Sourabh Raghuvanshi, A.K. Jhala. A fuzzy logic based static synchronous series compensator(SSSC) for enhancement of real power in a transmission line. International Research Journal of Engineering & Applied Sciences, IRJEAS, 2(3), pp. 57-60, 2014. https://www.irjeas.org/wp-content/uploads/admin/volume2/V2I3/V2I3_07140914_0012.pdf.
- [13]. Jiwani, N., & Gupta, K. (2019). Comparison of Various Tools and Techniques used for Project Risk Management. International Journal of Machine Learning for Sustainable Development, 1(1), 51-58. Retrieved from <https://ijsdcs.com/index.php/IJMLSD/article/view/119>
- [14]. Z.Huaang, Y. X. Ni, C. M. Shen, F. F. Wu, S. Chen, and B.Zhang, "Application of unified power flow controller in interconnected Power systems- modeling, interface, control strategy, and case study," IEEE Trans. Power Syst., vol. 15, pp. 811-816, May 2000.
- [15]. K.Manoz Kumar Reddy, "Improving the Dynamic and Transient Stability of the Network by the Unified Power Flow Controller (UPFC)", International Journal of Scientific and Research Publications, vol. 2, no.5, pp. 1-6, May 2012.
- [16]. N. Jiwani, K. Gupta and N. Afreen, "A Convolutional Neural Network Approach for Diabetic Retinopathy Classification," 2022 IEEE 11th International Conference on Communication Systems and Network Technologies (CSNT), 2022, pp. 357-361, doi: 10.1109/CSNT54456.2022.9787577.
- [17]. K. Gupta, N. Jiwani and N. Afreen, "Blood Pressure Detection Using CNN-LSTM Model," 2022 IEEE 11th International Conference on Communication Systems and Network Technologies (CSNT), 2022, pp. 262-366, doi: 10.1109/CSNT54456.2022.9787648.
- [18]. Shailesh Sharma, Paramjeet Kour. HVDC Power Transmission & Technology in India. International Research Journal of Engineering & Applied Sciences, IRJEAS, 2(1), pp. 34-40, 2014. https://www.irjeas.org/wp-content/uploads/admin/volume2/V2I1/V2I1_01140314_0007.pdf.
- [19]. N. Jiwani, K. Gupta and N. Afreen, "Automated Seizure Detection using Theta Band," 2022 International Conference on Emerging Smart Computing and Informatics (ESCI), 2022, pp. 1-4, doi: 10.1109/ESCI53509.2022.9758331.
- [20]. Manohar Murli, Sengar Ran vijay Singh. OPTIMIZED MAXIMUM POWER POINT TRACKING(MPPT) OF A SOLAR PV SYSTEM WITH IMPROVED P&O METHOD. International Research Journal of Engineering & Applied Sciences, IRJEAS, 4(1), pp. 07-11, 2016. <https://www.irjeas.org/wp-content/uploads/admin/volume4/V4I1/IRJEAS04V4I1011603160003.pdf>.
- [21]. Mukesh Kumar Mishra, Anurag Kulshrestha. ESTIMATION OF POWER GENERATION POTENTIAL OF AGRICULTURAL BASED BIOMASS SPECIES AND COAL- BIOMASS MIXED BRIQUETTES. International Research Journal of Engineering & Applied Sciences, IRJEAS, 5(1), pp. 01-06, 2017. <https://www.irjeas.org/wp-content/uploads/admin/volume5/V5I1/IRJEAS04V5I101170317000001.pdf>.
- [22]. Gabriela Hug-Glanzmann, Göran Andersson, "Decentralized Optimal Power Flow Control for Overlapping Areas in Power Systems". IEEE transactions on power systems, vol. 24, no. 1, February 2009.
- [23]. Hideaki Fujita, Yasuhiro Watanabe, Hirofumi Akagi, "Control and Analysis of a Unified Power Flow Controller". IEEE transactions on power electronics, VOL. 14, NO. 6, NOVEMBER 1999.
- [24]. Vani, Paramjeet Kour. Harmonic Analysis of Symmetrical and Asymmetrical Inverters. International Research Journal of Engineering & Applied Sciences, IRJEAS, 2(2), pp. 34-43, 2014. https://www.irjeas.org/wp-content/uploads/admin/volume2/V2I2/V2I2_04140614_0009.pdf.
- [25]. J.S. Uprit, Dr. A.M. Shandilya. Optimal Design of PV-WTG Hybrid Energy System. International Research Journal of Engineering & Applied Sciences, IRJEAS, 2(2), pp. 44-48, 2014. https://www.irjeas.org/wp-content/uploads/admin/volume2/V2I2/V2I2_04140614_0006.pdf.
- [26]. Subrat Kumar, Santosh Kumar. A REVIEW ON PROBABILISTIC MODELING BASED FORECASTING APPROACH TO PREDICT FUTURE PHOTOVOLTAIC POWER GENERATION. International Research Journal of Engineering & Applied Sciences, IRJEAS, 8(3), pp. 22-27, 2020. <https://www.irjeas.org/wp-content/uploads/admin/volume8/V8I3/IRJEAS04V8I307200920000004.pdf>.
- [27]. S. Kannan, Shesha Jayaram, M. M. A. Salama, "Real and Reactive Power Coordination for a Unified Power Flow Controller", IEEE transactions on power systems, VOL. 19, NO. 3, AUGUST 2004.
- [28]. N. Jiwani, K. Gupta and N. Afreen, "A Convolutional Neural Network Approach for Diabetic Retinopathy Classification," 2022 IEEE 11th International Conference on Communication Systems and Network Technologies (CSNT), 2022, pp. 357-361, doi: 10.1109/CSNT54456.2022.9787577.
- [29]. A. Eldamaty, S. O. Faried, S. Aboreshaid, "Damping power system oscillations using a fuzzy logic based Unified power flow controller". ©2005 IEEE CCECE/CCGEI, Saskatoon, May 2005.

